



Appendix A

20% Preliminary Engineering Plans and Design Reports



A-5

Methods of Construction Report, October 2020



Methods of Construction Report— Rev A

GPC6, C-2012668-02, Task Order #39 Dallas CBD Second
Light Rail Alignment (D2 Subway)

Final Draft - Concept Design

Dallas, Texas
October 9, 2019





Document Revision Record

Methods of Construction Report	HDR Report Number: <i>Click here to enter text.</i>
Project Manager: Tom Shelton	PIC: Tom Shelton

Revision Number: Rev. A, Final Draft – Concept Design	Date: Oct. 9, 2019
<i>Version 1</i>	<i>Date: Click here to enter text.</i>
<i>Version 2</i>	<i>Date: Click here to enter text.</i>

Originator	
Name: Changsoo Moon (Kevin)	Firm: HNTB Corp.
Title: National Tunnel Practice	Date: 09-30-2019

Commenters		
Name: Ernie Martinez Firm: DART Date: 12-11-2018	Name: Jim Sheahan Firm: HDR Date: 4-8-2019	

Approval	
Task Manager: Charles A. Stone	Date: 10-09-2019
Verified/Approved By: Ruben Manuelyan, Mala Cincia, Eric Wang	Date: 10-09-2019

Distribution		
Name: Tom Shelton	Title: Project Sponsor	Firm: HDR
Name: Ernie Martinez	Title: Project Manager	Agency: DART

This Report was Prepared for DART
General Planning Consultant Six Managed by HDR



Contents

1	Introduction	4
2	Overview of Construction Elements	4
3	General Ground Conditions	7
	3.1 Overburden	7
	3.2 Rock.....	8
	3.3 Groundwater	9
4	Construction Method for Tunnel U-Wall Approach Structures	9
	4.1 West Portal Retained Excavation	9
	4.1.1 General.....	9
	4.1.2 Ground and Groundwater Conditions	11
	4.1.3 General Configuration and Construction Approach	11
	4.2 East Portal Retained Excavation.....	11
	4.2.1 General.....	11
	4.2.2 Ground and Groundwater Conditions	12
	4.2.3 General Configuration and Construction Approach	12
5	Construction Method for Cut-and-Cover Tunnel Portals and Station Structures.....	13
	5.1 General Construction Considerations	13
	5.1.1 Bottom-Up Construction.....	13
	5.1.2 Top-Down Construction	13
	5.2 West Portal and Cut-and-Cover Excavation	14
	5.2.1 General.....	14
	5.2.2 Ground and Groundwater Conditions	15
	5.2.3 General Configuration and Construction Approach	15
	5.3 Metro Center Station	16
	5.3.1 General.....	16
	5.3.2 Ground and Groundwater Conditions	18
	5.3.3 General Configuration and Construction Approach	18
	5.4 Commerce St. Station	19
	5.4.1 General.....	19
	5.4.2 Ground and Groundwater Conditions	21
	5.4.3 General Configuration and Construction Approach	22
	5.5 CBD East Station.....	24
	5.5.1 General.....	24
	5.5.2 Ground and Groundwater Conditions	25
	5.5.3 General Configuration and Construction Approach	26
	5.6 East Portal and Cut-and-Cover Excavation.....	26
	5.6.1 General.....	26
	5.6.2 Ground and Groundwater Conditions	26



5.6.3 General Configuration and Construction Approach 26

6 Construction Method for Running Tunnels 27

6.1 Construction Method for Running Tunnels 27

6.1.1 Tunnel Boring Machine (TBM) 28

6.1.2 Sequential Excavation Method (SEM)..... 30

6.1.3 Cut-and-Cover Tunnels 31

6.2 General Construction Considerations 32

6.3 Major Features of Mined Tunnel Segments 33

6.3.1 West Portal to Metro Center Station 33

6.3.2 Metro Center Station to Commerce St. Station..... 33

6.3.3 Commerce St. Station to CBD East Station 34

6.3.4 CBD East Station to East Portal 35

6.4 Construction Shaft Metro Center Station 35

7 Construction Method for Cross Passages and Sump Pump Station 36

7.1 General Considerations..... 36

7.2 Construction Method for Cross Passages 37

7.3 Construction Method for Sump Pump Station 39

8 Tunnel and Station Waterproofing 40

8.1 Application to Underground Structures..... 40

8.2 Types of Waterproofing Systems 40

8.3 Waterproofing Systems for DART D2 Project 41

9 Potential Construction Sequencing..... 42

10 References..... 43

Tables

Table 2-1. Construction Elements, DART D2 Subway Tunnel (Current as of August 12, 2019)..... 4

Figures

Figure 2-1 Profile along Eastbound Track Alignment..... 6

Figure 4-1 West Portal Existing Utility Locations and Data..... 10

Figure 4-2 Typical U-Wall Section with Egress Walkway at Outside of Tracks 10

Figure 4-3 East Portal Existing Utility Locations and Data 12

Figure 5-1 Layout of the West Portal and Cut-and-Cover Excavation (as of 8/12/2019) 15

Figure 5-2 Layout of the Metro Center Station (as of 8/12/2019) 17

Figure 5-3 Mined Binocular Cavern Option for Metro Center Station 17



Figure 5-4 Cut-and-Cover Option for Metro Center 18

Figure 5-5 Example of Slurry Walls with Anchors for 55-foot deep SOE in Austin, TX (courtesy of Malcom Drilling)..... 19

Figure 5-6 Layout of the Commerce St. Station (as of 8/12/2019)..... 20

Figure 5-7 Low-Profile Station Cavern Cross-Section 20

Figure 5-8 High-Profile Station Cavern Cross-Section..... 20

Figure 5-9 High-Profile Station Cavern Cross-Section Profile at Sta. 70+00 21

Figure 5-10 Commerce St. Station Construction Stage Concept (DRAFT) 23

Figure 5-11 Side-Drift SEM Stage Concept for Commerce St. Station 24

Figure 5-12 Layout of the CBD East Station (as of 8/12/2019) 25

Figure 5-13 CBD East Station Cut-and-Cover Cross-Section 25

Figure 5-14 Layout of the East Portal and Cut-and-Cover 27

Figure 6-1 Typical TBM Running Tunnel Cross-Section with Precast Lining 29

Figure 6-2 Typical TBM Running Tunnel Cross-Section with Cast-in-Place Lining 29

Figure 6-3 Typical SEM Running Tunnel Cross-Section 31

Figure 6-4 Cut-and-Cover Running Tunnel Cross-Section 32

Figure 6-5 As-Built Drawing for the Storm Sewer between Commerce St. and Pearl Expressway 34

Figure 6-6 Status of Utility Impact by Storm Sewer at East Cut-and-Cover and Mined Running Tunnel Section 35

Figure 7-1 Cross-Passage Longitudinal Section..... 37

Figure 7-2 Cross-Passage Section for Class I Rock 38

Figure 7-3 Cross-Passage Section for Class II Rock 38

Figure 7-4 Sump/Pump Station Tunnel Profile and Cross-Sections 39



1 INTRODUCTION

This Methods of Construction Report (MCR) describes feasible methods anticipated to be used for construction of the underground structures of the DART D2 light rail tunnel project, based on the Locally Preferred Alternative (LPA) alignment current as of August 12, 2019 and the concept design current as of October 9, 2019. The report covers the only the underground guideway portion of the LPA alignment, which extends under North Griffin and Commerce Streets and south of Swiss Street.

The scope of the construction addressed in this report includes U-wall sections, cut-and-cover running tunnels and underground stations, mined running tunnels, a mined underground station, cross-passages, a sump and pump room, ventilation and egress shafts, and entrances and ancillary structures. The report also discusses feasibility of alternative methods available for construction of the underground structures.

These descriptions of methods of construction are provided at the conceptual level of design completion, a design level of approximately 10%. They are based on available historical record and published geotechnical information and DART D2 geotechnical data presented in the *Geotechnical Data Report (GPC6, 2019a)*. Additional geotechnical detail will be provided in future reports.

2 OVERVIEW OF CONSTRUCTION ELEMENTS

The DART D2 light rail subway project is to be procured as a Design-Build Contract, with underground structures and construction elements as shown in Table 2-1. A profile along the eastbound track alignment is shown in Figure 2-1. As of October 2019, the effort to identify affected subsurface structures and foundations along the alignment corridor is still ongoing.

TABLE 2-1. CONSTRUCTION ELEMENTS, DART D2 SUBWAY TUNNEL (CURRENT AS OF AUGUST 12, 2019)

Structure	Anticipated Construction Method	Approximate Stationing		Approximate Length, ft	Approximate Top of Rail Elevation, ft
		From	To		
West Portal U-Wall Section & Headwall	Open Cut	35+29.77	41+50.00	620	Varies
West Portal Running Tunnel	Cut-and-cover or SEM Twin Bore (optional)	41+50.00	44+80.00	330	Varies
		44+80.00	49+26.58	447	
Metro Center Station	Cut-and-cover	49+26.58	54+22.42	496	370



Structure	Anticipated Construction Method	Approximate Stationing		Approximate Length, ft	Approximate Top of Rail Elevation, ft
		From	To		
West Twin Bore Running Tunnel	TBM or SEM	54+22.42	68+05.00	1,383	365
Commerce Street Station Cavern	SEM	68+05.00	75+26.10	721	354
East Twin Bore Running Tunnel	TBM or SEM	75+26.10	86+29.61	1,103	Varies
East Running Tunnel	Cut-and-cover or SEM Twin Bore (optional)	86+29.61	93+13.09	683	Varies
CBD East Station	Cut-and-cover	93+13.09	98+05.17	492	430
East Portal Running Tunnel	Cut-and-cover	98+05.17	101+55.23	350	Varies
East Portal U-Wall Section & Headwall	Open Cut	101+55.23	107+60.00	605	Varies
Cross-Passage 1	SEM	61+00.00		18	-
Cross-Passage 2	SEM	80+00.00		18	-
Cross Passage 3 (optional) ⁽³⁾	SEM	87+00.00		18	-
Pump/Sump Station	SEM	66+25.00			-

Notes:

1. Structure locations and dimensions are based on alignment current as of Aug. 12, 2019.
2. Cross passage and pump/sump station stationing is at structure center line. Length is perpendicular to running tunnels.
3. Cross Passage 3 applies only to the SEM option for the segment between the east end of the TBM tunnel and the west limit of the CBD East station and shall be omitted if a cut-and-cover tunnel option is selected for this segment.

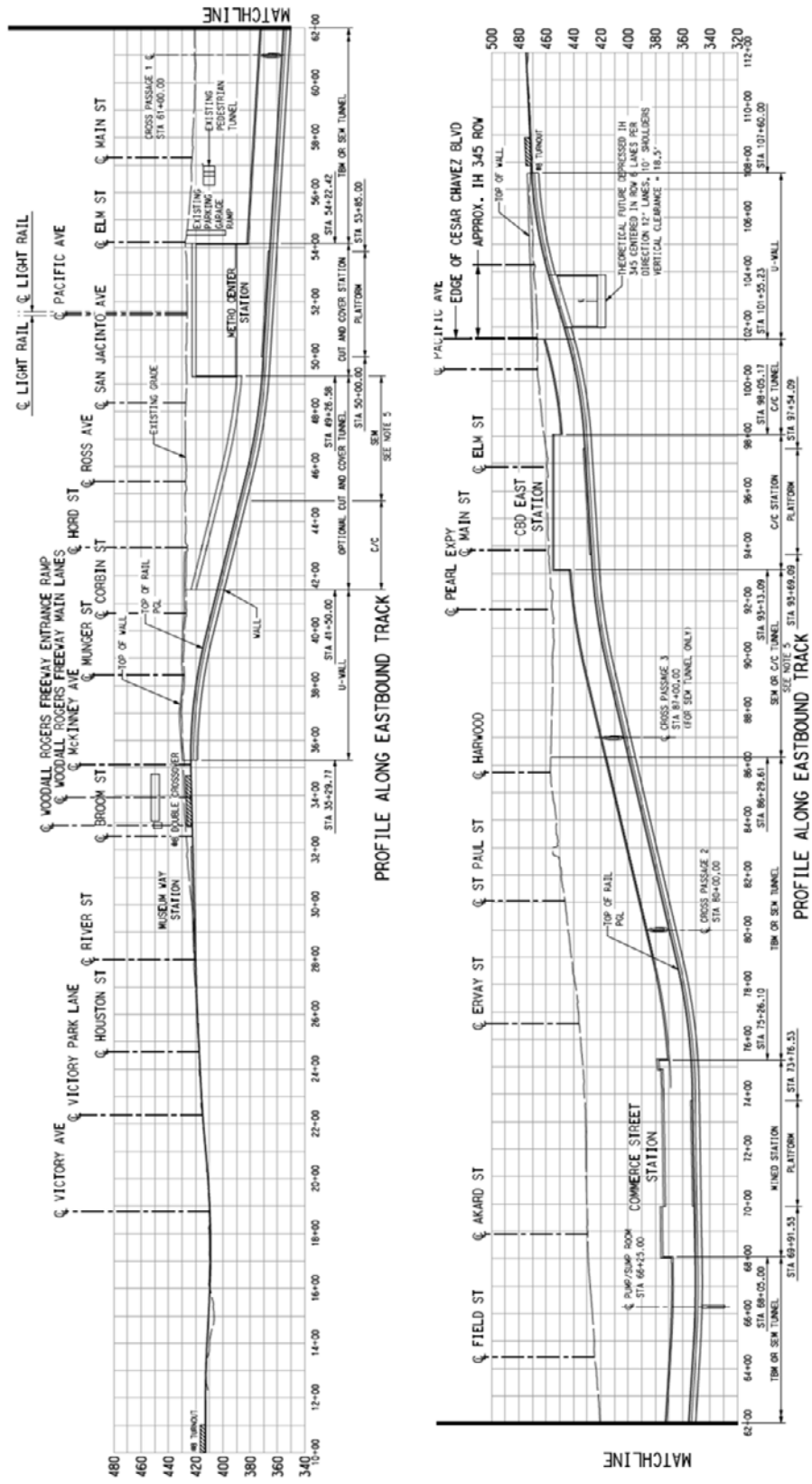

Figure 2-1 Profile along Eastbound Track Alignment



3 GENERAL GROUND CONDITIONS

This section provides a general summary of subsurface conditions along the D2 LPA alignment. More detailed information is provided in the GDR (GPC6 2019a), *Technical Memorandum 3* (GPC6, 2019b), *Geotechnical Design Memorandum 11* (GPC6, 2019c), and *Geotechnical Design Memorandum 9* (GPC6, 2019d).

Subsurface conditions along the underground segments of an earlier LPA alignment and draft geotechnical data are described in Technical Memorandum #3 (TM 3), “Preliminary Ground Characterization” (GPC6, 2019b). Descriptions are anticipated to be generally applicable to the current alignment. A geotechnical design memorandum describing ground conditions based on data in the final GDR (GPC6, 2019a) and the current LPA alignment is in preparation.

Descriptions and thicknesses presented in the paragraphs below are from TM 3 (GPC6, 2019b) and may be revised based on more recent information in the GDR (GPC6, 2019a).

3.1 Overburden

Overburden along the alignment consists of fill, cohesive alluvium, granular alluvium, and residual soil. Overburden will be encountered in excavations for portal open cuts and in cut-and-cover sections at the portals, Metro Center Station, CBD East Station, and the running tunnels west of CBD East Station.

Fill along the alignment is stiff to hard clay with locally variable amounts of sand and silt and traces of gravel, brick, concrete, and limestone fragments. Maximum fill thickness along the alignment is anticipated to be about 5 feet.

Cohesive alluvium is fine-grained and consists of low- to high-plasticity clays and sandy and silty clays. Thickness ranges from 1 foot to 30.5 feet in the DART D2 alignment area, averaging 13.0 feet. These soils are susceptible to consolidation settlement if additional stresses are imposed on them, including any increased effective stress from groundwater lowering. The cohesive alluvium soils are also highly expansive.

Granular alluvium consists of cohesionless soils ranging from silty sands to sand and gravel and clayey sand. Maximum thickness in the DART D2 alignment area is about 14 feet and average thickness is about 6.6 feet. These soils are likely to exhibit running behavior in excavations above the water table and flowing behavior below the water table, especially where they consist of clean sand and gravel.

Residual soils could not be distinguished on boring logs but if present would likely be very stiff to hard moderately to highly plastic clay.

See TM 3 (GPC6, 2019b) for additional detail on characteristics of overburden materials.



3.2 Rock

Weathered rock is present beneath the alluvium and any residual soils in the DART D2 alignment area. The weathered rock is typically described as moderately hard to hard, tan to gray weathered limestone and occasionally as decomposed limestone with clay seams. Thickness ranges from 1 foot to about 10.5 feet. Weathered rock will likely be encountered in excavations for cut-and-cover sections at the portals, Metro Center Station, CBD East Station, and the running tunnels west of CBD East Station.

Beneath the weathered rock is limestone of the Austin Chalk, the formation through which most of the D2 rock excavation will take place. The limestone is described as white to light gray, medium hard to hard, and unweathered to slightly weathered, with shale seams and calcareous layers. Bedding typically dips 0 to 15 degrees to the east. Fractures, which include bedding plane fractures and non-bedding plane fractures, are spaced from less than 2 inches apart to more than 6 feet apart. Typical unconfined compressive strength for limestone along the DART D2 alignment is between about 1,500 and 4,000 pounds per square inch (psi).

Limestone will be encountered in all excavations except for portions of the open cuts at the portals.

Shale of the Eagle Ford Group underlies the limestone. The shale in the DART D2 alignment area is gray to dark gray, fine-grained, soft to medium hard, and unweathered to slightly weathered. Bedding typically dips 0 to 15 degrees to the east, and many, but not all, fractures occur along bedding planes. The shale includes hard and very hard calcareous layers as well as sandy mudstone, fine-grained sandstone, and scattered layers of soft clay shale and limestone less than 2 inches thick. Typical unconfined compressive strength for Eagle Ford shale in the DART D2 alignment area is between about 300 and 2,500 psi.

Shale could be encountered along the alignment in running tunnel and stations excavations from Metro Center Station to Commerce Station.

Except for its hard, calcareous layers, the Eagle Rock shale is moderately to highly erodible, with cut slopes susceptible to both rapid mass movements and long-term creep. The clay shales have a moderate to very high swell potential. Cyclical wetting and drying tends to accelerate degradation of the shale.

Bentonite layers up to about 1 foot thick and parallel to bedding planes are present in both the limestone and the shale. If exposed to moisture after drying, clays in the bentonite layers will slake and swell to many times their original volume, potentially inducing slabbing and separation along bedding planes in rock.

No major fault zones appear to cross the DART D2 alignment, but small-displacement normal faults are abundant. Faults typically have slickensided surfaces and dip 45 to 60 degrees in various directions. None of the faults are active.

See TM 3 (GPC6, 2019b) for additional detail on intact rock properties and rock mass characteristics.



3.3 Groundwater

No in-situ hydraulic conductivity testing has been performed for DART D2 investigations to date. Hydraulic conductivity in limestone along the alignment is anticipated to be up to about 1×10^{-2} to 1×10^{-3} cm/sec in overburden and up to about 1×10^{-5} cm/sec in rock. Regionally, the Austin Chalk is a productive water supply aquifer, but use of the Eagle Ford shale as an aquifer is very limited.

Groundwater levels along the DART D2 alignment are typically 12 to 22 feet below the ground surface and most often about 5 feet above to 1 foot below the top of weathered rock.

Hydrocarbons have been identified in groundwater in downtown Dallas, and their source is believed to be abandoned underground fuel oil tanks (TM3 GPC6, 2019b).

See TM 3 (GPC6, 2019b) for additional detail on groundwater conditions.

4 CONSTRUCTION METHOD FOR TUNNEL U-WALL APPROACH STRUCTURES

4.1 West Portal Retained Excavation

4.1.1 GENERAL

Based on the LPA alignment current as of August 12, 2019, the West Portal U-Wall section will be located within the parking lot northeast of Old Griffin Street between McKinney Avenue and Hord Street.

An existing utility line has been identified as a major obstruction crossing at Munger, Corbin, Hord, Ross and Griffin Streets. The sizes of the utility lines under those streets appear to be between 6- and 8-inch diameter, and they are similar to the lines along other streets. The location of the utility line is shown in Figure 4-1. Additional nearby utilities are listed in the Utility Index also shown in Figure 4-1. Figure 4-2 shows the typical U-wall section with egress walkway at inside of tracks.

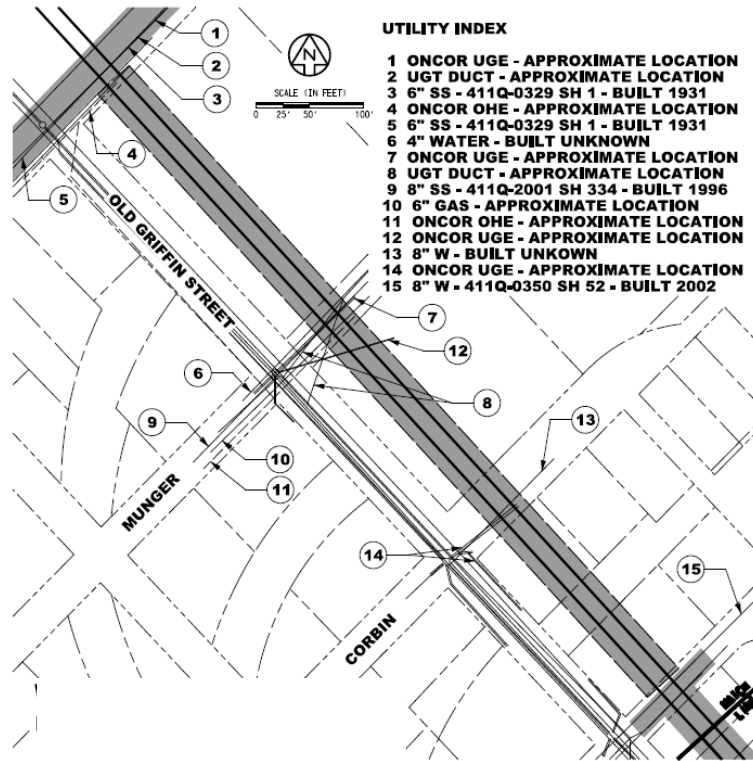

Figure 4-1 West Portal Existing Utility Locations and Data

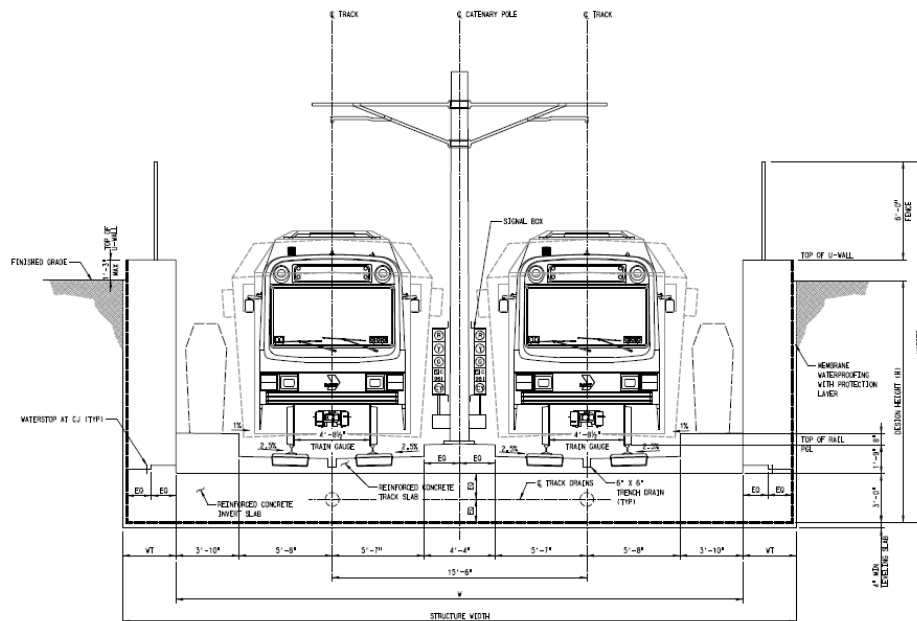

Figure 4-2 Typical U-Wall Section with Egress Walkway at Outside of Tracks



4.1.2 GROUND AND GROUNDWATER CONDITIONS

Two DART D2 borings have been drilled within the West Portal Retained Excavation section. Based on information in the GDR (GPC6, 2019a) and TM 3 (GPC6, 2019b), about 60 to 80 percent of the volume to be excavated in this section will be alluvium. The remaining portion will be excavated in fill and weathered rock, with some slightly weathered limestone present near the invert excavation.

No groundwater level measurements were available for TM 3 (GPC6, 2019b), but the boring logs report water seepage at depth 19.5 feet below ground surface during drilling of boring T-6 and at depth 18 feet below ground surface during drilling of T-102. These levels correspond to groundwater levels at elevations +411 and +410 feet.

Site-specific ground and groundwater condition data presented in the final GDR (GPC6, 2019a) will be incorporated in future reports.

4.1.3 GENERAL CONFIGURATION AND CONSTRUCTION APPROACH

The height of the approach structures will vary, to a maximum of 38 ft, and they can be constructed using rigid support of excavation (SOE) systems such as secant pile walls, slurry diaphragm walls, or flexible SOE soldier-piles and lagging before the placement of the permanent concrete structure. Alternatively, a combined engineered slope and short wall system may be considered feasible for northern side of approach structure if existing parking lot easement can be obtained.

The SOE system will be selected by Contractor based on actual site conditions and means-and-methods. The SOE wall will extend up from the cast-in-place invert slab with internal bracing to support the walls if necessary. The permanent concrete walls may be used as the foundation for the catenary support structures. Protective barriers will be erected at the top of the walls for protection against the electrified contact wires as well as for fall protection.

The U-wall retaining structure at the West approach will be constructed by maintaining access to all driveways, keeping construction completely within the public right-of-way. Per GDM #11 non-driven drilled pile foundation systems are viable support of excavation (SOE) for the unique project constraints, including existing geotechnical and surface site conditions.

4.2 East Portal Retained Excavation

4.2.1 GENERAL

At the East Portal U-Wall section, the existing storm sewer along North Olive Street has been identified as an obstruction and should be relocated during the open-cut excavation and U-wall construction. The impact zone is approximately 30 feet long near Sta. 104+00. The utility locations are shown in Figure 4-3.

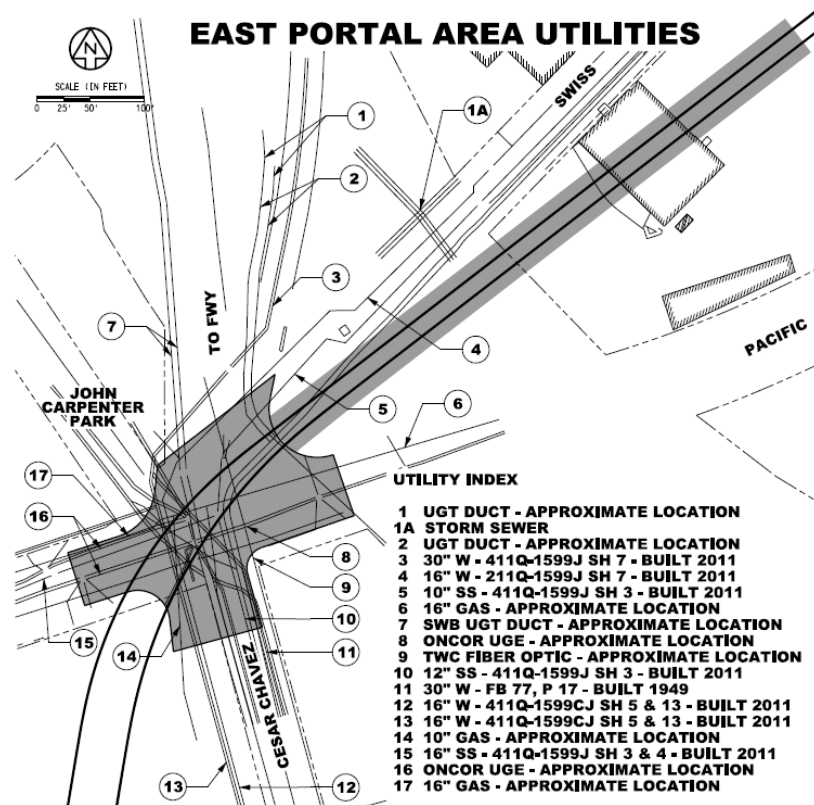

Figure 4-3 East Portal Existing Utility Locations and Data

4.2.2 GROUND AND GROUNDWATER CONDITIONS

One DART D2 boring has been drilled within the limits of the East Portal Retained Excavation. The boring log for boring P-102 indicates that excavation in this section will be primarily in clayey alluvium with a 1-foot thick layer of more sandy alluvium. The excavation is also anticipated to encounter fill and a minor amount of weathered rock.

No groundwater level measurements were available for TM 3 (GPC6, 2019b), but the boring log reports water seepage at depth 14 feet below ground surface, corresponding to a groundwater level at elevation +456 feet.

Site-specific ground and groundwater condition data presented in the final GDR (GPC6, 2019a) will be incorporated in future reports.

4.2.3 GENERAL CONFIGURATION AND CONSTRUCTION APPROACH

The East Portal structures will require open cut construction with a suitable SOE method, compatible with the ground conditions. Per GDM #11 feasible SOE at east portal U-Wall section approach structures may include pre-drilled rock-socketed soldier piles-and-lagging system.



Excavation and construction of open cut U-wall sections that follow an existing street alignment will generally require relocation of utilities. The major obstacles for constructing these portal structures have been identified and are presented in Technical Memorandum 16 (GPC6, 2019e), “Utility Conflicts at Portals and Underground Stations.” Early identification of utility conflicts will help avoid unscheduled delays during detailed design and construction.

Because the open cut will be crossing under IH 345, with more than 20 feet of vertical clearance, protection of the existing pier foundation will be a major construction consideration in the section.

5 CONSTRUCTION METHOD FOR CUT-AND-COVER TUNNEL PORTALS AND STATION STRUCTURES

Cut-and-cover structures, including running tunnels and underground stations, can be feasibly constructed using the either conventional bottom-up or top-down construction techniques. Internally braced rigid SOE systems such as slurry wall or secant pile wall keyed into bedrock are both applicable options in more congested downtown locations. These construction methods are described in the following sections.

5.1 General Construction Considerations

The cut-and cover construction method has been used for running tunnel and station construction on many projects. The rectangular box shape is a practical cross-section which has been adopted to this construction method. Two different cut-and-cover techniques are possible for DART D2 construction: bottom-up construction and top-down construction.

5.1.1 BOTTOM-UP CONSTRUCTION

Bottom-up construction is a conventional construction method for cut-and-cover structures. The street would be closed until installation of concrete decking for temporary traffic. Then, the utilities would be relocated and suspended from under the decking beam, which serves as a top bracing structure. Subsequently, the main excavation would extend down to the grade elevation of the invert by adding several tiers of the bracing or anchoring system, as needed. A temporary drainage system such as the French drain would be considered to release the hydrostatic pressure at the bottom of invert. Upon completion of the tunneling, the permanent structure would be constructed from the bottom elevation up to the top of structure, as the installed bracing system is sequentially removed.

5.1.2 TOP-DOWN CONSTRUCTION

Top-down construction is an alternative method for cut-and-cover structure where right-of-way constraints govern choice of construction method. The final structure would be

constructed by following the excavation stage from the top to the bottom. In order to implement this method, interlocking secant pile wall and/or concrete diaphragm wall systems would be considered permanent structures. The major advantage of this construction concept is the utilization of the SOE as both of a temporary and a permanent structure. Consequently, construction cost would likely be less than for the conventional construction bottom-up staging plan. In addition, temporary decking could be removed once the permanent roof structure is installed, which would be earlier than for the conventional method. This method would reduce community impacts, especially to the downtown business district.

One disadvantage with this method is that local (U.S.) contractors may be less familiar and/or experienced with this construction approach than with the conventional bottom-up method.

5.2 West Portal and Cut-and-Cover Excavation

5.2.1 GENERAL

The western portion of the underground alignment will be in proximity to buildings on either side of North Griffin Street which include the following high-rise structures:

- The Dallas World Aquarium
- Homewood Suites by Hilton Dallas Downtown
- Crowne Plaza Dallas Downtown
- Bank of America Plaza Dallas
- One Main Place

This section of the alignment also crosses under the following rail system:

- DART Light Rail Transit System (Blue, Green, Orange, and Red Lines)

The existing light rail line is located at ground surface elevation +430 feet at approximate Sta. 51+50 in the Pacific Avenue. The impact of this facility on the DART D2 project is that the underground running tunnels will have to be constructed while the existing line remains in service.

For each of these structures, both pre- and post-construction condition surveys will be required. In addition, structural and geotechnical instrumentation will be required to monitor each building's performance during and after tunnel, station or shaft excavation.



Figure 5-1 Layout of the West Portal and Cut-and-Cover Excavation (as of 8/12/2019)

5.2.2 GROUND AND GROUNDWATER CONDITIONS

One DART D2 boring has been drilled within this section. The boring log indicates that excavation in this section will be entirely in limestone.

No groundwater level measurements were available for TM 3 (GPC6, 2019b), however based on the boring log, water seepage was observed at depth 19 feet below ground surface during drilling of boring T-103, corresponding to a groundwater level at elevation +409 feet.

Site-specific ground and groundwater condition data presented in the final GDR (GPC6, 2019a) will be incorporated in future reports.

5.2.3 GENERAL CONFIGURATION AND CONSTRUCTION APPROACH

Per GDM #11 feasible SOE at west portal cut-and-cover section approach and headwall structures may include pre-drilled rock-socketed soldier piles-and-lagging system at locations where overhead clearance is available. Both conventional bottom-up and top-down construction approaches are feasible for cut-and-cover running tunnel sections.

Cut-and-cover construction would be performed from the surface and normally located within public right-of-way or on underdeveloped land such as parking lots, parks, or vacant lots. Where located within a street, this type of construction would consist of successive stages in following general procedure:

- 1) Close half the width of the street to traffic for one block, install support of excavation and relocate or suspend utilities.
- 2) Excavate to a minimal depth (say 10-15 feet).
- 3) Install temporary decking panels over the excavation.



- 4) Restore traffic.
- 5) Repeat this process on the other side of the street.
- 6) Move to the next block and repeat.

Upon installation of decking, construction would generally proceed as follows:

- 1) Excavate full depth under the temporary decking, install internal bracing and/or external tiebacks or rock bolts as required, while excavation progresses.
- 2) Perform dewatering as excavation progresses.
- 3) Monitor ground movements and building settlements adjacent to the excavation.
- 4) Upon completion of the required excavation, install successively a mud slab, waterproofing membrane and structural invert slab.
- 5) Construct the exterior walls of the permanent structure, extending the waterproofing membrane as the walls go up.
- 6) Re-support the excavation from the partially completed permanent structure using permanent floor slabs, and remove internal bracing as construction progresses, and stop dewatering.

5.3 Metro Center Station

5.3.1 GENERAL

The LPA vertical alignment current as of August 12, 2019 (See Figure 5-2) including the planned Metro Center Station situated with nominally sufficient rock cover for a mined station with binocular cross-section. Additional subsurface investigations and testing will be required to ascertain the feasibility of implementation of mining methods for this station. Both mined (Figure 5-3) and cut-and-cover construction (Figure 5-4) were identified as feasible for construction of Metro Center Station based on the limited available subsurface data and the anticipated shallow cover conditions.

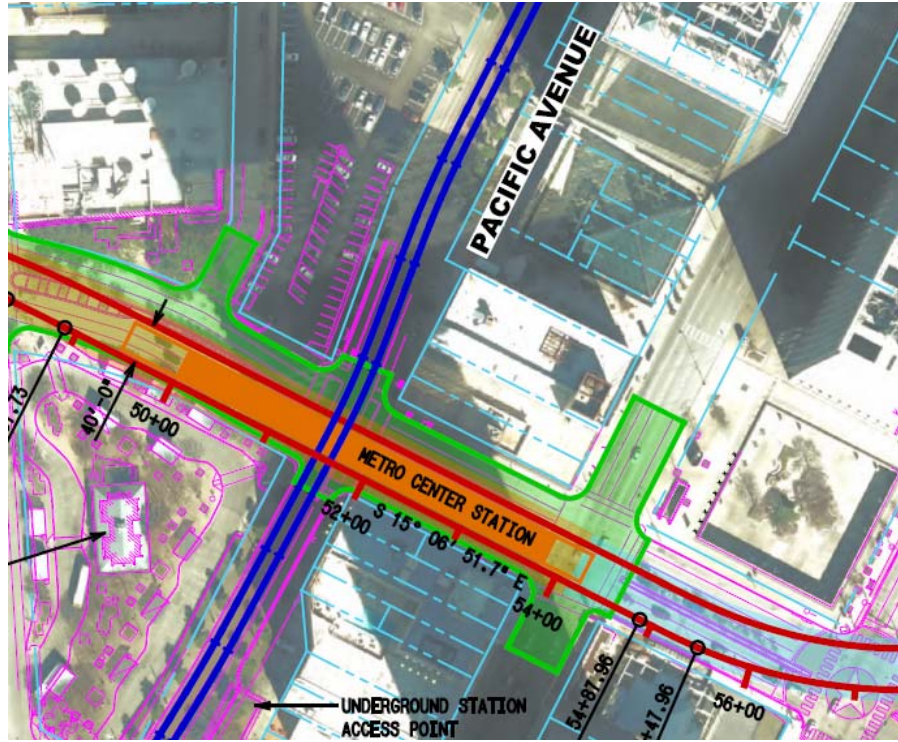

Figure 5-2 Layout of the Metro Center Station (as of 8/12/2019)

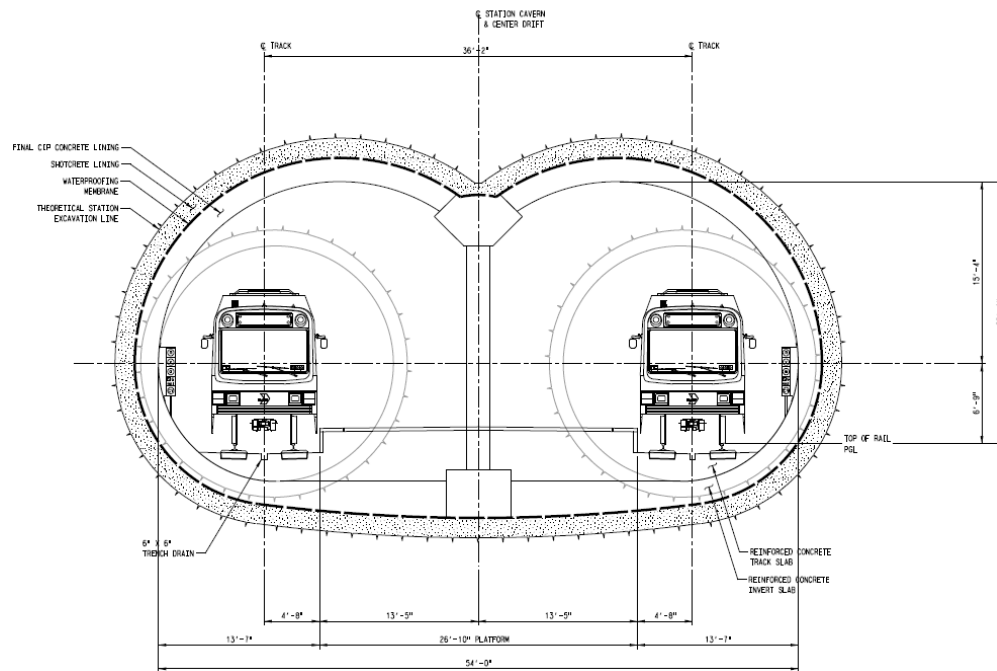

Figure 5-3 Mined Binocular Cavern Option for Metro Center Station

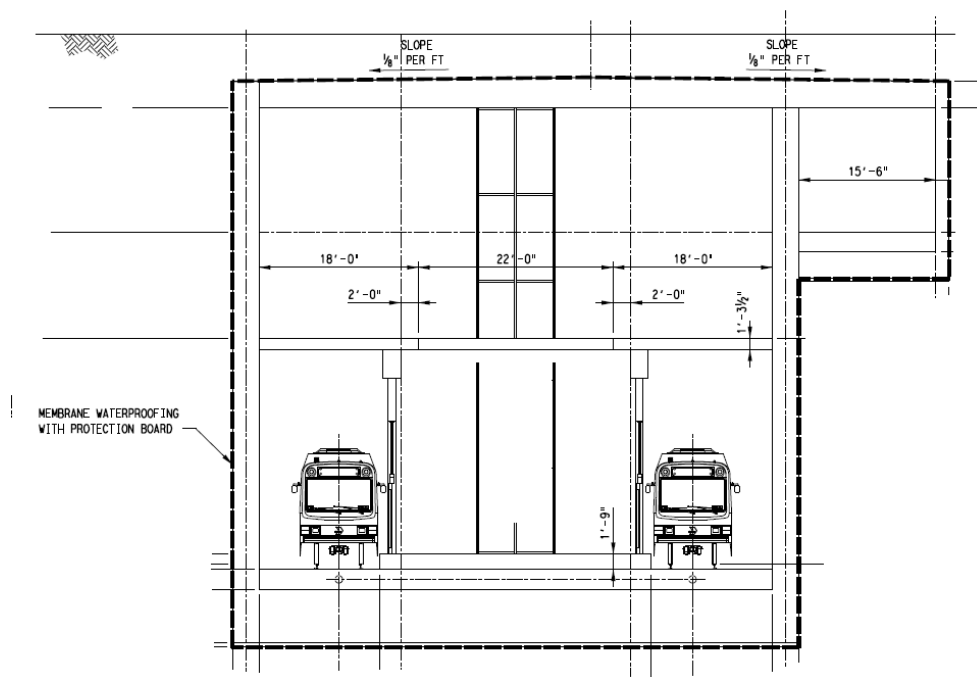

Figure 5-4 Cut and Cover option for Metro Center

5.3.2 GROUND AND GROUNDWATER CONDITIONS

Two DART D2 borings have been drilled within this section. Based on the boring logs, excavation for the Metro Center Station will be primarily in limestone. Some shale will also be encountered.

No groundwater level measurements were available for TM 3 (GPC6, 2019b), but boring logs report water seepage at depth 20 feet below ground surface drilling of boring B-1 and at depth 19 feet below ground surface during drilling of TS-104, corresponding to groundwater levels at elevations +407 feet and +408 feet.

Site-specific ground and groundwater condition data presented in the final GDR (GPC6, 2019a) will be incorporated in future reports.

5.3.3 GENERAL CONFIGURATION AND CONSTRUCTION APPROACH

A mined station was considered feasible at Metro Center Station. However, the configuration would have to consist of a sequential excavation method (SEM), mined, 60-foot wide binocular station cavern with center platform and ceiling height of 33 feet, as shown in Figure 5-3. A wider platform width would accommodate a larger passenger capacity and accommodate a transition to the existing bus terminal. As a result, the cut and cover station would be a more favorable construction method for accommodating this requirement than the mined binocular station option.

Both secant pile and slurry walls with bracing and anchors systems are feasible to provide for the temporary SOE (see Figure 5-5).



Figure 5-5 Example of Slurry Walls with Anchors for 55-foot deep SOE in Austin, TX (courtesy of Malcom Drilling)

5.4 Commerce St. Station

5.4.1 GENERAL

The layout of Commerce Station current as of August 12, 2019 is shown in Figure 5-6.

A more complex multi-stage construction approach will be required to build the mined underground station within this downtown location. Major existing utilities within the planned station limits will need to be protected prior to the SEM excavation. Both low-profile (Figure 5-7) and higher-profile (Figure 5-8) cross-sections will be used within the station limits to accommodate the unique site constraints. Specifically, as shown in Figure 5-10 - Commerce St. Station Construction Staging Concept the main access to the station cavern will be constructed from the headhouse vertical shaft and passenger adit tunnel to the mezzanine level in the high-profile station cross-section configuration. Also, the low-profile cross-section will be constructed within the normal platform alignment to minimize the impact on existing utilities.

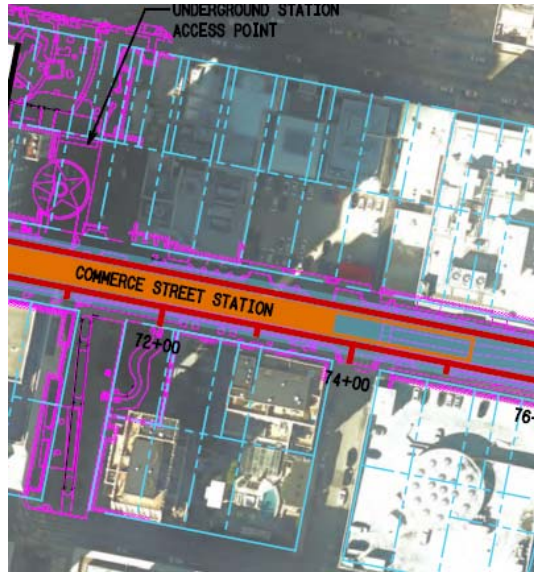

Figure 5-6 Layout of the Commerce St. Station (as of 8/12/2019)

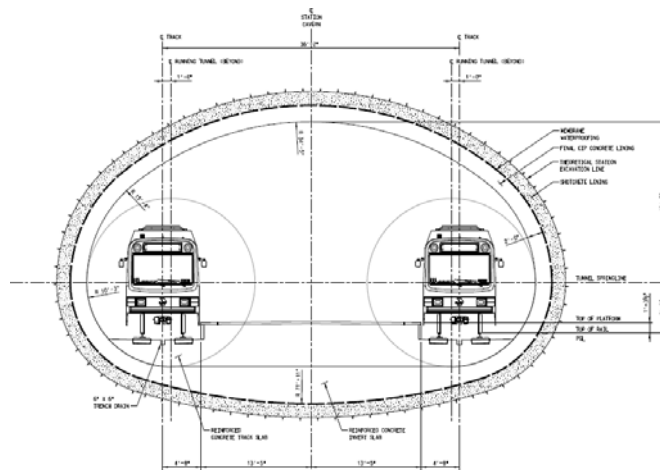

Figure 5-7 Low-Profile Station Cavern Cross-Section

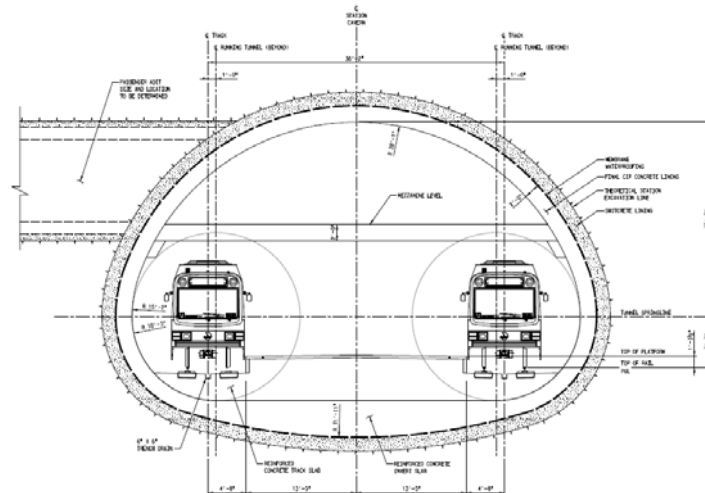

Figure 5-8 High-Profile Station Cavern Cross-Section



5.4.2 GROUND AND GROUNDWATER CONDITIONS

Three DART D2 borings have been drilled in this section. Based on the boring logs, rock to be excavated the Commerce Station Cavern will be predominantly limestone, including some poorer quality limestone. Shale is also anticipated to be encountered in the invert excavations for Commerce Station Cavern, which allowed consideration of a single arch SEM cavern as shown in Figure 5-9.

No groundwater level measurements from completed borings or wells were available for TM 3 (GPC6, 2019b). Boring logs report water seepage at depth 12.5 feet below ground surface during drilling of boring TS-202 and at depth 14 feet below ground surface drilling of boring B-3, corresponding to groundwater levels at elevations +417 and +423 feet.

Site-specific ground and groundwater condition data presented in the final GDR (GPC6, 2019a) will be incorporated in future reports.

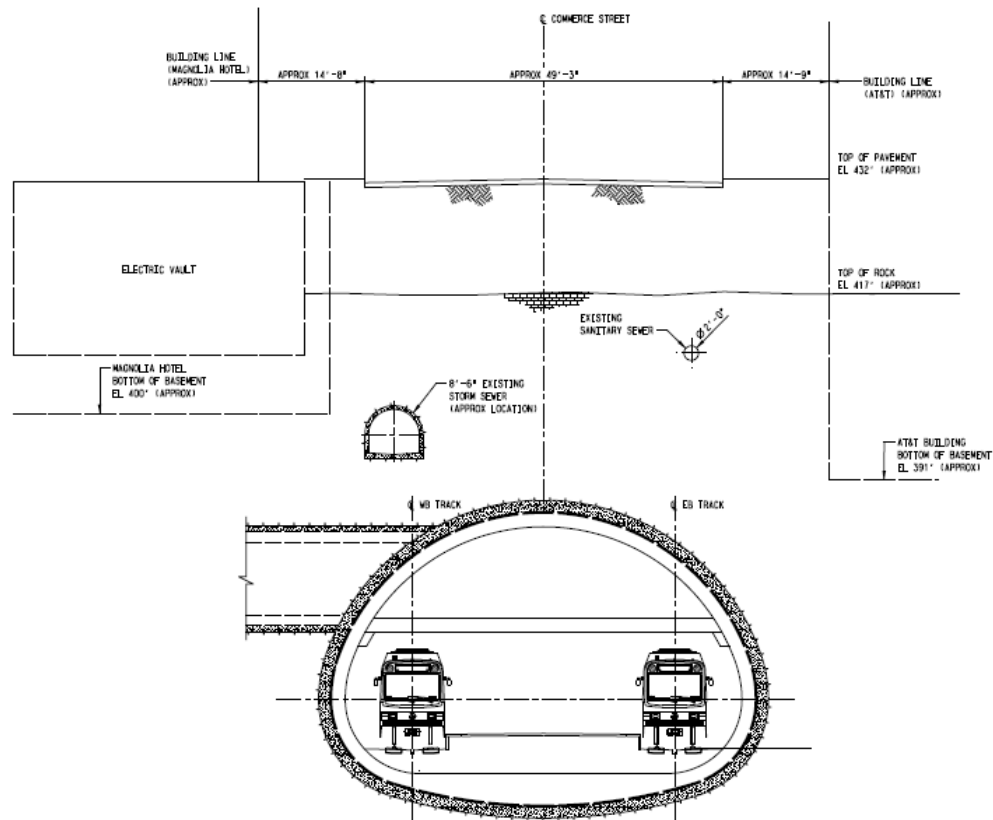

Figure 5-9 High-Profile Station Cavern Cross-Section Profile at Sta. 70+00

5.4.3 GENERAL CONFIGURATION AND CONSTRUCTION APPROACH

The SEM construction method strives to retain the inherent strength of the surrounding rock mass by timely installation of a temporary (initial) support system for each phase of the excavation sequence. For a more in-depth discussion, see TM #08 - Assessment of Minimum Rock Cover Over Station Crown (GPC6, 2019f).

Station cavern linings are typically constructed in two stages, commencing with the initial lining that constitutes temporary excavation support and stabilizes the excavated opening immediately following the excavation activities. It is followed by the completion of the final lining and waterproofing. Initial linings, at their simplest form, may consist of a few rock bolts in the crown followed by a layer of shotcrete reinforced by steel fibers, traditional reinforcement rebars, or wire mesh. Usually, additional reinforcement is accompanied by lattice girders; also, longer rockbolts in a denser pattern may be needed. The final lining must accommodate all the loading that the structure will be subjected to during its service life and is typically cast-in-place concrete. In between the initial and final linings, a waterproofing membrane accompanied by a protective layer of a woven fleece (geotextile) is installed.

The main access to the station cavern will be constructed from the headhouse vertical shaft at Pegasus Plaza and the secondary access may be considered through the ventilation shaft from the Lane St.

The side-drifting sequential excavation method, one of excavation operation options including the application of a sprayed shotcrete initial lining is shown in Figure 5-11.

Depending on the rock mass quality and rock cover, the center drifting may be an alternative excavation staging method.

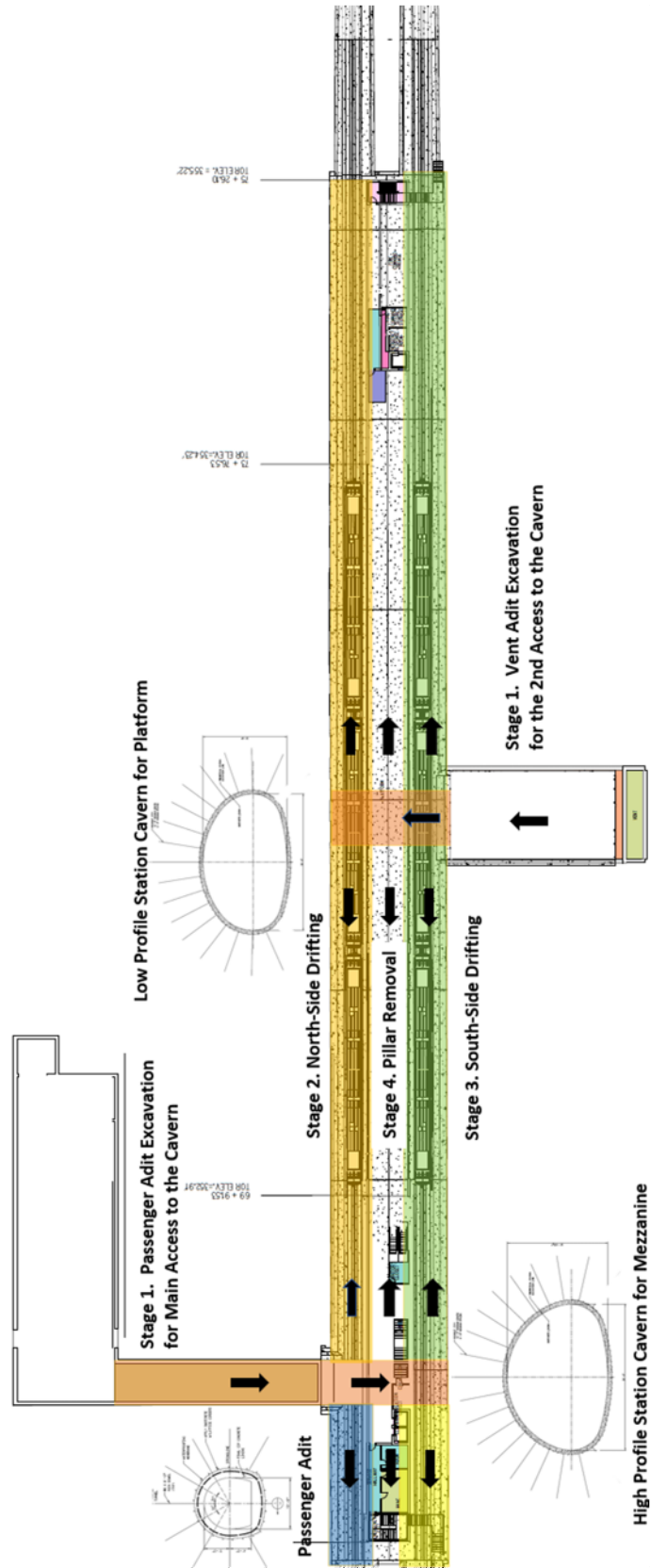

Figure 5-10 Commerce St. Station Construction Stage Concept (DRAFT)

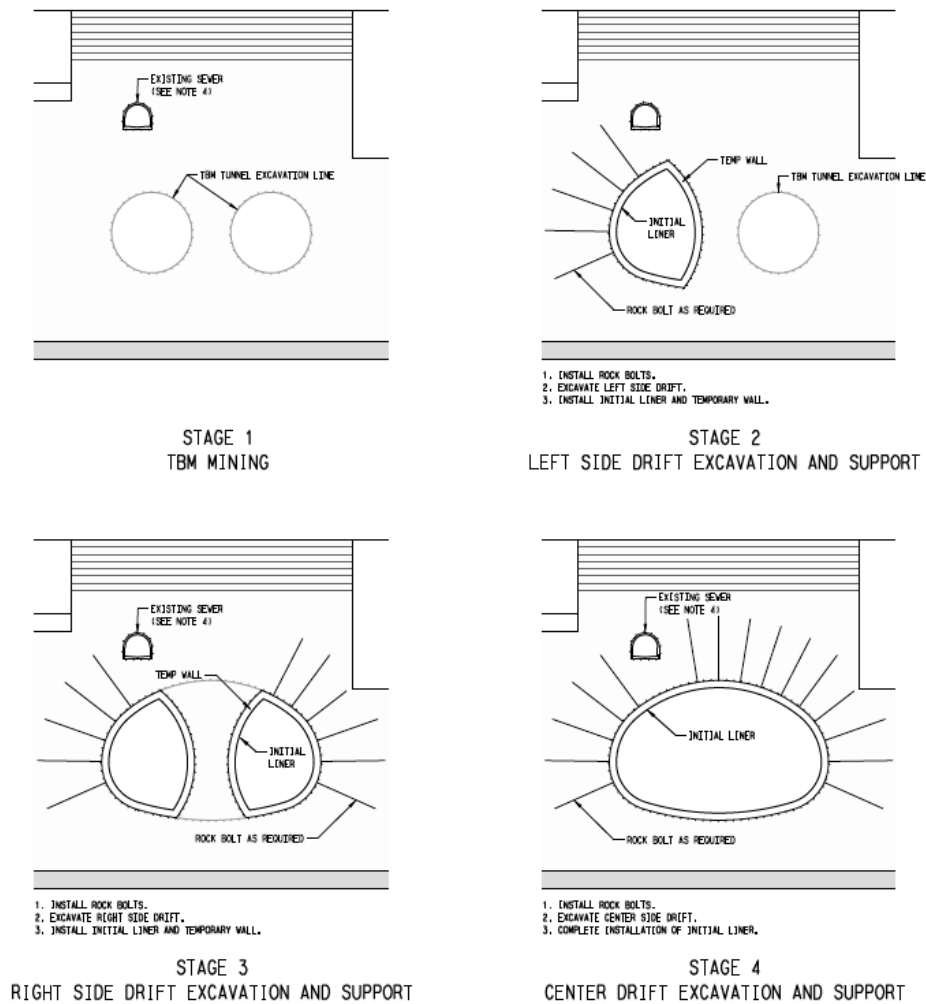

Figure 5-11 Side-Drift SEM Stage Concept for Commerce St. Station

5.5 CBD East Station

5.5.1 GENERAL

The planned CBD East Station is located in areas where shallow rock cover conditions are anticipated. Each of these station profiles has been raised in the 10% South of Swiss Alignment, Aug. 12, 2019 such that these stations could be constructed by the cut-and-cover excavation methods.

Key considerations for the feasibility of cut-and-cover station construction include available right-of-way limits, presence of and construction impacts to existing utilities and building foundations as well as surface impacts (impacts to streets and traffic, noise, dust, vibrations, and access restrictions) on nearby communities and businesses.

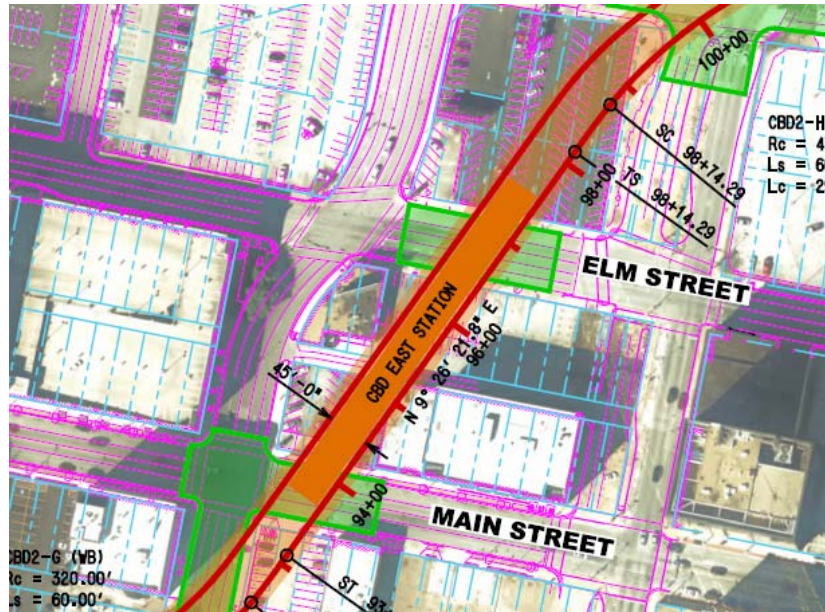

Figure 5-12 Layout of the CBD East Station (as of 8/12/2019)

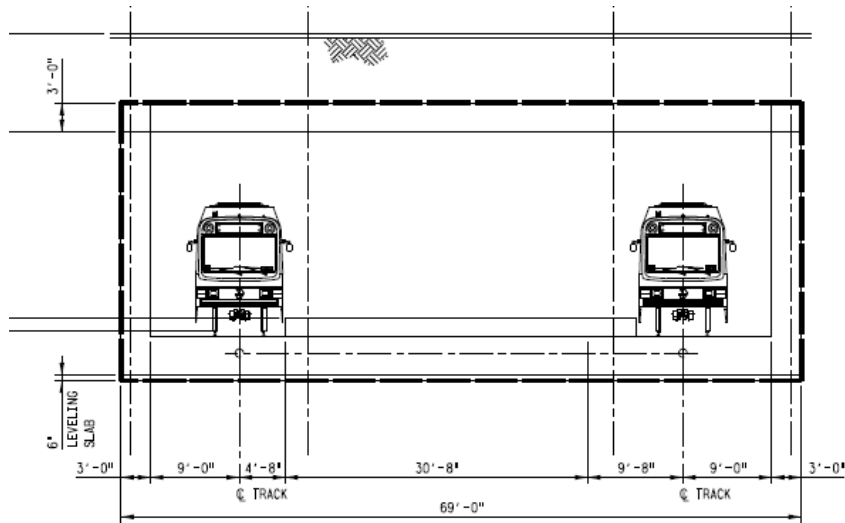

Figure 5-13 CBD East Station Cut-and-Cover Cross-Section

5.5.2 GROUND AND GROUNDWATER CONDITIONS

One boring has been drilled in this section. Based on the boring log, the thickness of overburden to be excavated CBD East Station will be up to about 38 feet, at approximately elevation +423 feet.



No groundwater level measurements were available for TM 3 (GPC6, 2019b), but the boring log reports water seepage at depths corresponding to a groundwater level at elevation +442 feet.

Site-specific ground and groundwater condition data presented in the final GDR (GPC6, 2019a) will be incorporated in future reports.

5.5.3 GENERAL CONFIGURATION AND CONSTRUCTION APPROACH

In the original LPA, this station was planned to be constructed at the location of an existing parking garage which is supported on a deep foundation. However, that LPA does not provide enough rock cover for a mined station under the parking garage. Thus, cut-and-cover construction, similar to the cross-section shown in Figure 5-13, was considered and the alignment was adjusted (shifted to the east) to avoid the interference with the Elm St. parking garage.

5.6 East Portal and Cut-and-Cover Excavation

5.6.1 GENERAL

This section depth is relatively shallower than the West portal and cut-and-cover section based on the track alignment current as of August 12, 2019. The unique site constraints require use of a steeper than typical vertical gradient of approximately 6% to accommodate the presence of existing IH 345 viaducts.

5.6.2 GROUND AND GROUNDWATER CONDITIONS

One DART D2 boring (TS-112) has been drilled in this section. Based on the boring log, rock excavation in this section will primarily be in limestone. The anticipated overburden will be mostly alluvium, including clayey alluvium and more sandy alluvium. Fill and a small amount of weathered rock at the boundary are also expected within limits of this excavation.

No groundwater level measurements were available for TM 3 (GPC 6, 2019), but the boring log reports water seepage at depth 19.2 feet below ground surface during drilling of boring TS-112, corresponding to a groundwater level at elevation +448 feet.

Site-specific ground and groundwater condition data presented in the final GDR (GPC6, 2019a) will be incorporated in future reports.

5.6.3 GENERAL CONFIGURATION AND CONSTRUCTION APPROACH

This section will consist of the cut-and-cover tunnel with minimum 400-ft of curve and 6% of vertical gradient. The cut and cover tunnel section will need to install the concrete decking for the live traffic during construction period. But in the parking garage yard after the CBD East Station section, the decking system may not be necessary for the public protection.



Figure 5-14 Layout of the East Portal and Cut-and-Cover

6 CONSTRUCTION METHOD FOR RUNNING TUNNELS

Available mechanical excavation methods for underground excavations in rock include mining by Tunnel Boring Machine (TBM) and roadheader excavation. The economics of excavation is site-specific, and typically favors one method over the other depending on the strength and abrasiveness of the rock, local geologic factors, presence of nearby and overlying structures and compliance with applicable local vibration limitations at nearby structures. The Contractor will select the construction method for the running tunnel based on these and considerations described in the following sections.

6.1 Construction Method for Running Tunnels

The selection of a mining method for tunnel excavation is based on tunnel alignment in plan and profile, subsurface features including ground features and types and locations of obstructions along tunnel alignment, required ground support type, and local conditions along the selected alignment that might influence the tunneling. The primary methods for excavating the running tunnels for the DART D2 alignment are as follows:

- Tunnel Boring Machine Excavation – Single Shield (Open/Closed), Open Beam
- Sequential Excavation Method (SEM)
- Cut-and-Cover box construction

Portal sections consisting of a succession of earth retaining U-wall and cut-and-cover box structures are required at each end of the mined tunnel segment up to a location where the tunnel profile deepens sufficiently to allow mining operations.

The starting and ending portals for the mined tunnel will be located in cut-and-cover pits at the West and the East portions of the alignment. The potential presence of methane gas would greatly increase the temporary ventilation system requirements in order to minimize construction downtime.

6.1.1 TUNNEL BORING MACHINE (TBM)

The TBM method of excavation is described briefly in this section and addressed in detail in Geotechnical Design Memorandum (GDM) #02 – Underground Excavation Methods (Contract No. GPC6, 2019g). A mechanized method by means of TBMs can be selected from several types of machines based on the local geology. Hydrostatic conditions and economy.

A TBM excavates the tunnel using a full-face cutter head. TBM tunnels with single-pass precast concrete segmental lining (Figure 6-1) are commonly used. In this type of construction, precast concrete segments are assembled immediately in the tail shield in the form of successive rings, to constitute the permanent lining.

If an open-beam TBM is selected, a cast-in-place lining (Figure 6-2) is placed following the excavation. In this case, the ground surrounding the excavation is stabilized by means of an initial support system and the exposed surface is smoothed with a shotcrete layer. This is followed by placement of the waterproofing membrane and casting of the concrete lining. Advances in TBM technology and equipment for soft rock tunneling have demonstrated that both methods could provide a safe and a high-quality construction.

The single shield with Earth Pressure Balance (EPB) function will be one option, depending on the Contractor's decision based on additional geological/geotechnical investigation results and the Contractor's subsequent risk management effort. However, it will be mandatory for the Contractor to meet the allowable groundwater drawdown criterion in order to avoid initiating any potentially excessive ground surface/building/structure settlements by mining activities.

One of the most time consumption processes of single shield TBM mining in soft rock would be the assembly of precast concrete segmental rings in relation to the rate of TBM advance. Normally, assembly would take approximately 35 to 50 minutes per ring depending on workman skill/ machine efficiency and segments delivery process. Thus, if the tunnel length to be pressurized due to excessive groundwater ingress is relatively short, the anticipated delay by EPB excavation would not cause significant impact on the construction schedule.

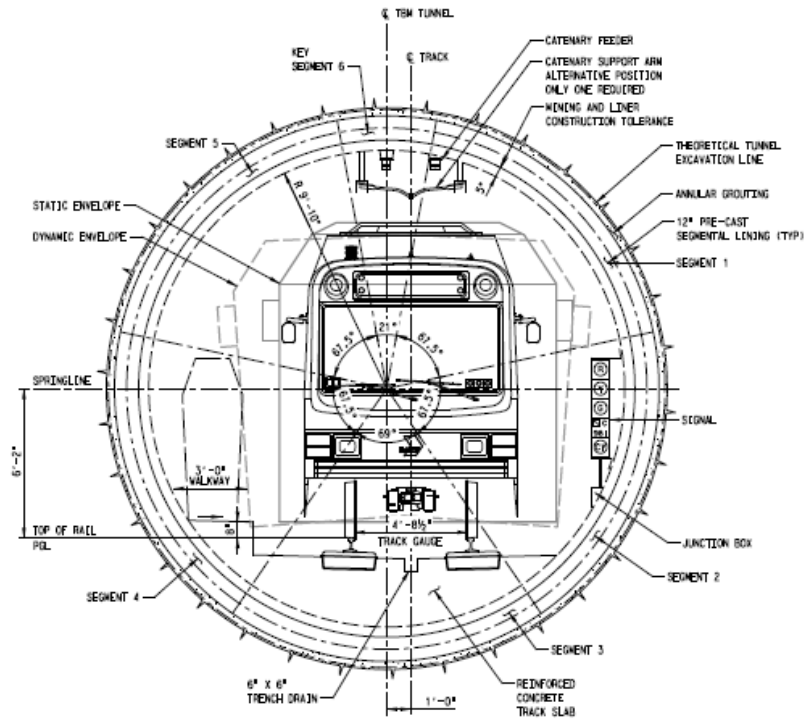

Figure 6-1 Typical TBM Running Tunnel Cross-Section with Precast Lining

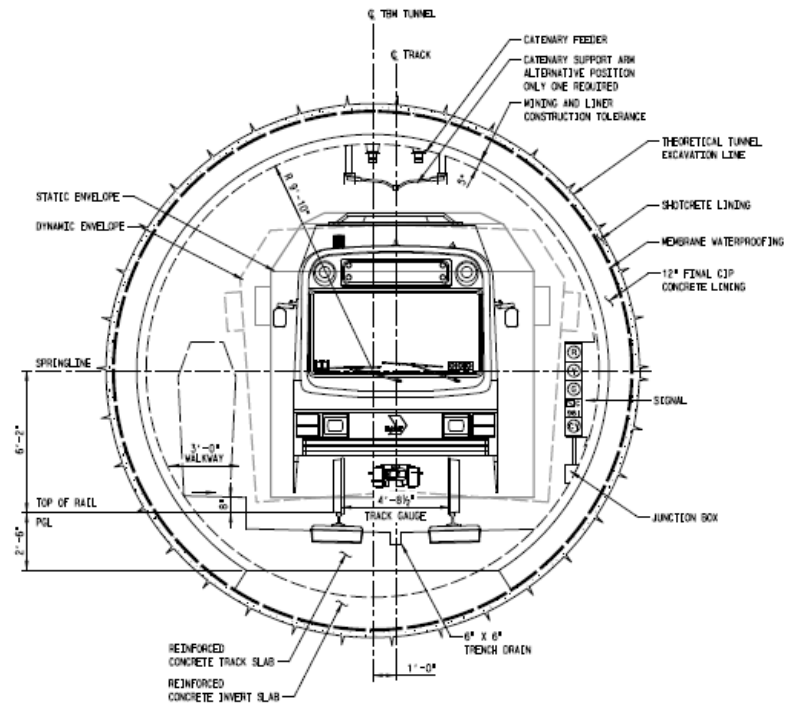

Figure 6-2 Typical TBM Running Tunnel Cross-Section with Cast-in-Place Lining



TBM excavation presents, however, limitations with respect to alignment curvatures. Along the present August 12, 2019 alignment, the tunnel takes on a curve with a 320 feet minimum radius to the east of Harwood Street, which would preclude the use of a conventional TBM with typical precast concrete liner system and would require customized segmental liner design and a shield machine with a short main body. These customized features will significantly raise the construction cost, thus, tunnel construction to the East of Sta 86+30 would be by the SEM and cut-and-cover method.

Considering this condition, the running tunnel launching portal for the TBM will be located in the cut-and-cover station site of Metro Center Station, and the receiving will be located in a cut-and-cover section to the west of Sta 86+30. With the resulting approximately 2,500 feet of mined tunnel, it is expected that TBM excavation would achieve cost and schedule savings, which would offset the additional time and cost associated with the acquisition of the TBM. Due to the project location in downtown of the city, slurry type shield TBM was not considered for this project.

6.1.2 SEQUENTIAL EXCAVATION METHOD (SEM)

Mining of tunnels performed by SEM is also known as the New Austrian Tunneling Method (NATM), or the observational tunneling method, where the excavation proceeds in drifts of top and bench headings, followed immediately by installation of temporary (initial) supports selected on basis of observed ground response. After application of a smoothing shotcrete layer and installation of the waterproofing membrane, the final cast-in-place (CIP) liner is constructed as the permanent (final) support of the tunnel, as shown in Figure 6-3. The sequential excavation using a roadheader or a mechanical excavator is an alternative method for excavation of the DART D2 running tunnels. Mechanical excavation methods in the Austin Chalk have previously been demonstrated successfully.

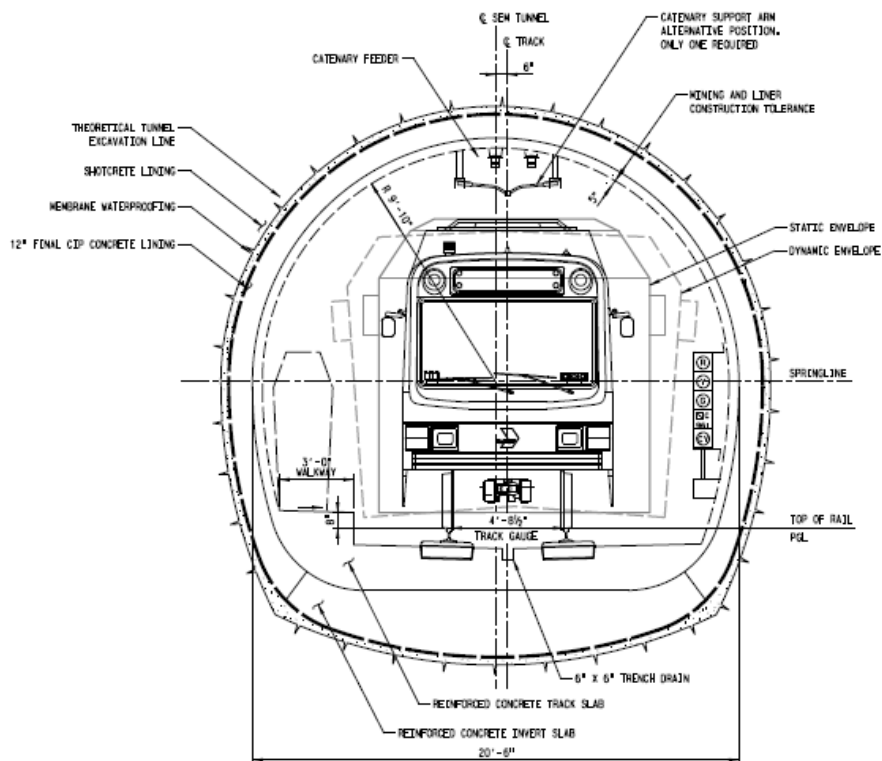

Figure 6-3 Typical SEM Running Tunnel Cross-Section

6.1.3 CUT-AND-COVER TUNNELS

In addition to function as transitional sections between at-grade trackways and deep tunnels, cut-and-cover box structures (Figure 6-4) may be constructed in segments of the alignment where sharp horizontal curves would not permit the use of TBMs, as an alternative to tunneling by SEM.

The disadvantage of cut-and-cover tunneling method is the need to occupy the street level as well as the need to control the traffic during installation and removal of the temporary decking system. In addition, excavation volume larger than for mined tunnels would add to the cost of such construction.

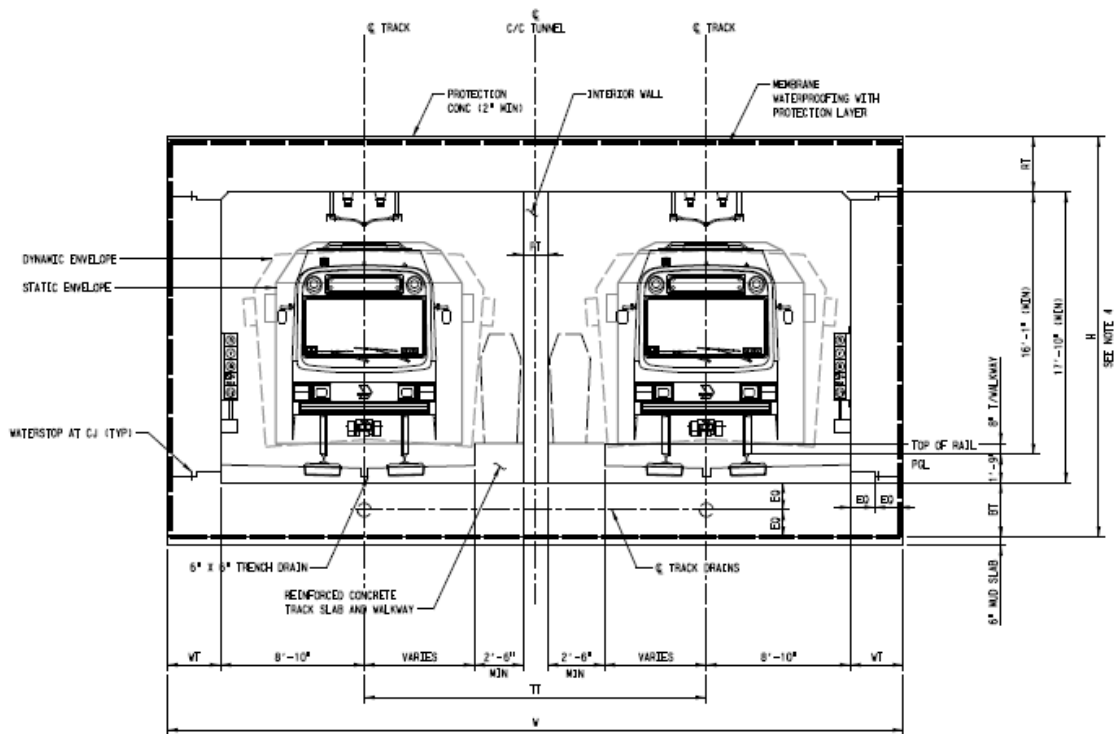

Figure 6-4 Cut-and-Cover Running Tunnel Cross-Section

6.2 General Construction Considerations

Due to the rock mass condition along the running tunnel alignment, it would be feasible to use the single shield TBM or the sequential excavation method (SEM) for tunnel alignment where limited access from the surface is available. The following TBM features will be required for this segment.

For an open beam hard rock TBM, which would be outfitted with disc cutters designed for soft rock conditions such as the Austin Chalk formation of this project, and provided that sufficient rock cover is present, the thrust force applied to the tunnel sidewalls by the side gripper pads of the machine is a critical factor. Therefore, it is recommended that the Contractor confirm the in-situ rock mass properties, rock cover and pillar thickness to evaluate the feasibility and the required features, such as adjustability of gripper force, in utilizing this type of machine.

As the TBMs will mine through rock mass, wearing of the cutting tools will occur. The TBM should have the capability for easy tool removal and replacement, which under the prevailing groundwater conditions may not necessitate hyperbaric intervention. For this reason, two-pass tunneling with the permanent cast-in-place concrete liner and waterproofing membrane installed after completion of the TBM excavation is a feasible option. However, a single shield TBM with precast concrete segment liner would reduce multiple construction sequences and achieve higher quality than the double pass tunneling method. Thus, a single pass TBM system where waterproofing is achieved by gaskets at the



joints between segments, is more favorable and recommended for this tunnel, which being undrained does not require a special waterproofing system.

Considering the potential of methane gas seeping through the faults and other zones of poorer and weathered/fractured rock, it will be mandatory for any type of TBM system to be suitably equipped with an appropriate non-flammable gas monitoring system designed for gaseous ground conditions.

In spite of the TBM methods inherent quality of construction, and the cost effectiveness associated with long mined tunnels, due to the short running tunnel distances between stations, and as caused by the sharp curve east of Harwood Street, this method may result in higher overall construction cost than the conventional SEM tunneling. Therefore, the Contactor should also consider the SEM in final design.

The running tunnels for the DART D2 project can technically be excavated by TBM boring, roadheader excavation, but not by drill and blast excavation methods due to prohibition by the Owner. None of these methods are ruled out by technical considerations. A restriction on blasting, however, would leave TBM boring and roadheader excavation as the only two acceptable mined methods of mechanized excavation for the running tunnels.

6.3 Major Features of Mined Tunnel Segments

6.3.1 WEST PORTAL TO METRO CENTER STATION

This section extends from Sta. 41+50 to Sta. 49+27 and will be constructed either entirely cut-and-cover or a cut-and-cover followed by SEM tunnel. Underground utilities identified in this segment are an 8" water main, multiple electrical cables, 6" to 12" sanitary sewers, an 8" gas main and several telephone ducts. These utility lines shall be temporarily relocated or protected under the temporary decking systems, where interfering with cut-and-cover construction. Secant pile walls are recommended for the support of excavation (SOE) system of cut-and-cover construction in this section.

6.3.2 METRO CENTER STATION TO COMMERCE ST. STATION

The existing parking garage entrance structure directly above the new starter tunnel is a major obstacle at the East bulkhead of the Metro Center station box. This entrance structure is crossing the Elm St. with a shallow rock cover. The Contractor will need to identify the exact as-built condition in relation to the tunnel alignment and geotechnical/geological conditions. The second major construction issue in this sector will be the sharp curve of the tunnel alignment with minimum 440-foot radius, approaching Commerce Street from the S. Griffin Street under the Belo Garden. Special consideration of the TBM specification would be necessary to accommodate this tight curve within allowable tolerances and for ensuring the short and long term structural stability.



6.3.3 COMMERCE ST. STATION TO CBD EAST STATION

A potentially considerable impact on the running tunnel construction should be anticipated from the existing storm sewer between St. Paul Street and S. Pearl Expressway under Commerce Street, and between Commerce Street and Main Street under S. Pearl Expressway. The existing storm sewer tunnel invert elevation is approximately +401 to +407 feet and the inner diameter varies from 7 to 5-feet as per the as-built drawing dated 09-21-1959 as shown in Figure 6-5. The impact zone is approximately 1,200-feet between Sta. 81+00 and Sta. 93+00, as shown in Figure 6-6. The existing storm sewer may be relocated by routing it via Main Street and Harwood Street. A micro tunnel boring machine (MTBM) with three or more new vertical shafts may be considered feasible to perform the relocation of existing storm sewer.

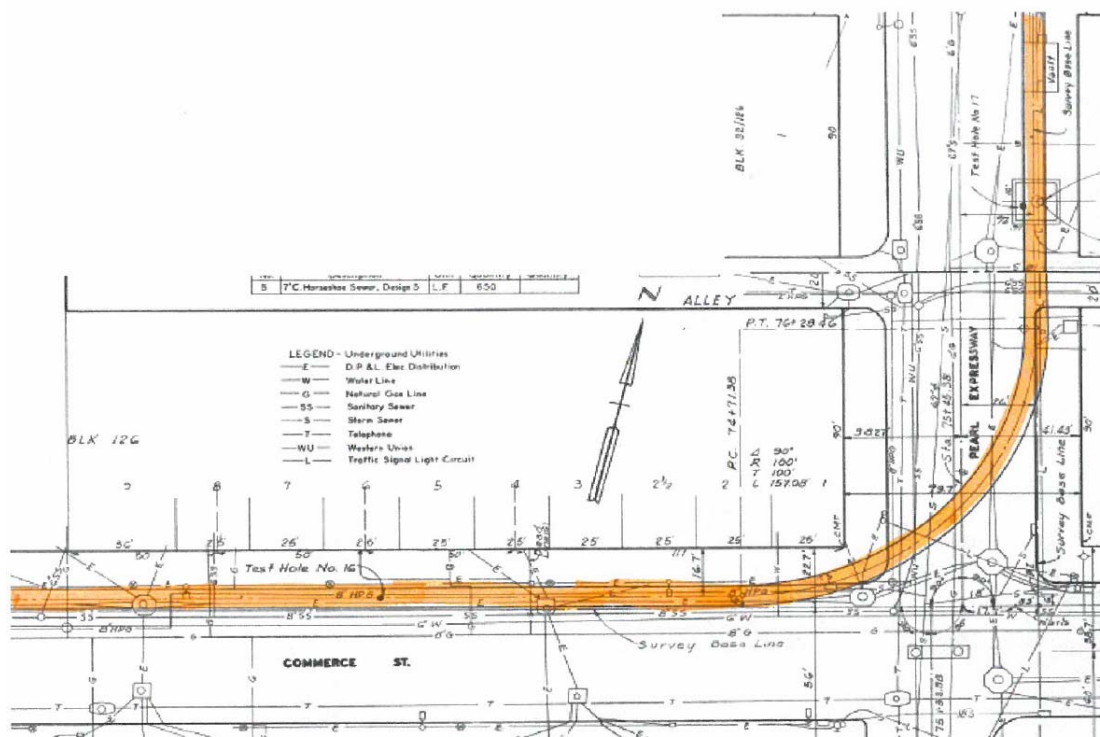

Figure 6-5 As-Built Drawing for the Storm Sewer between Commerce St. and Pearl Expressway

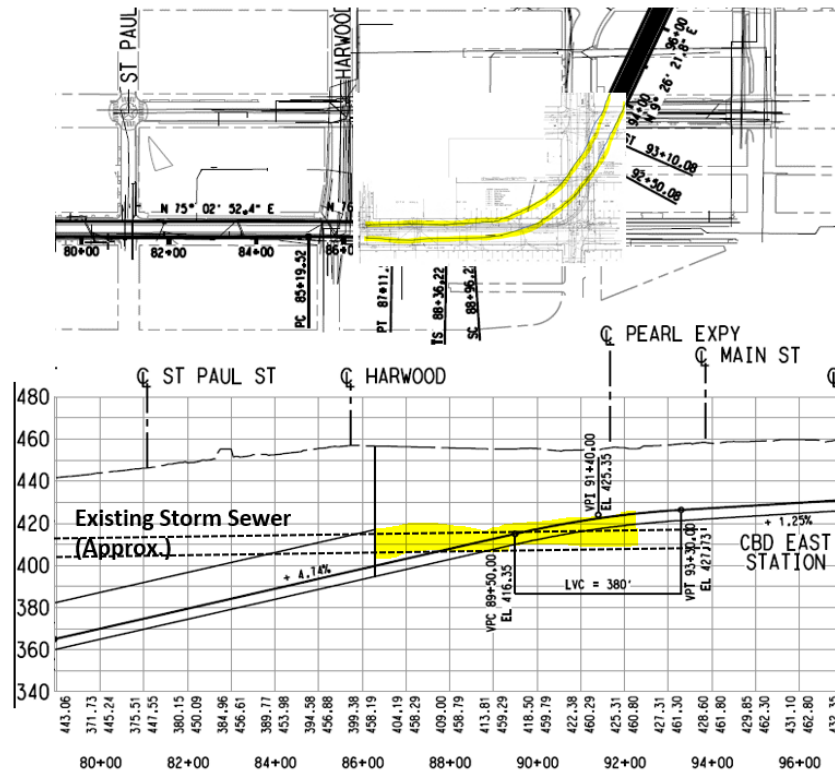

Figure 6-6 Status of Utility Impact by Storm Sewer at East Cut-and-Cover and Mined Running Tunnel Section

A second sharp curve with minimum 320-feet and 356-feet radii will be accommodated by a cut-and-cover tunnel. Alternatively, a tunnel mined by SEM may be feasible to be for this sharp curve. A TBM tunnel is precluded for this segment because of the sharp horizontal curve and the steep vertical gradient of 4.74%, which would require greater thrust to advance the TBM.

6.3.4 CBD EAST STATION TO EAST PORTAL

A cut-and-cover tunnel will be constructed in this section, which comprises a third sharp curve with minimum 400-feet and 470-feet radii. The TBM and SEM mined tunnel may not be feasible to be constructed in this segment due to the shallow rock/ground cover and a vertical gradient as high as 6.0%.

6.4 Construction Shaft Metro Center Station

A construction shaft may be necessary for the excavation of the Commerce Street Station cavern. The location of this shaft will be determined in conjunction with the planned station entry/ventilation structures. In addition, other potential shaft structures for ventilation/emergency egress and station entrances will be evaluated once their locations are fully developed via architectural plans in the future.



Internally-braced flexible SOE systems are considered viable for construction of ventilation and station entrance shafts per GDM 11.

7 CONSTRUCTION METHOD FOR CROSS PASSAGES AND SUMP PUMP STATION

7.1 General Considerations

Based on the NFPA 130 (NFPA), cross passages are required to be constructed at intervals of not more than 800 feet. Based on this criterion, 2 cross passages are to be excavated between mined TBM and/or SEM tunnel bores for the running tunnels of the DART D2 project. If the option of an SEM tunnel is adopted for segment west of the CBD East station, then a third cross passage will be added in that segment. These cross passages connecting the Eastbound and Westbound egress walkways as shown in Figure 7-1 will be located at Sta. 61+00, Sta. 80+00 and Sta. 87+00, and will have cross sections as shown in Figures 7-2 and 7-3, depending on the classification of the surrounding rock per GDM #3.

Opportunities to eliminate these cross-passages for any alignment alternative may be available should station limits be changed during design development.

These structures are described in more detail in GDM #09 – Construction of Cross Passages, Alcoves, and Pump Rooms (Contract No. GPC6, 2019d).

A sump and pump station will be located at the lowest point of the alignment (Sta. 66+25), with a capacity to extract the quantities of water expected from firefighting activities in the tunnel.

Special considerations for temporary ventilation and drainage system will be required for the construction and public safety concern. As stated in the GDM #09, the construction sequence will be decided by the Contractors as to whether start mining after completion of the station cavern excavation or executing both excavations simultaneously with the utilization of double track California switch at the junction between the running tunnel and the sump/pump station tunnel.

Regardless of the ground condition, probe drilling for verification of the geotechnical and geological condition shall be a mandatory process prior to partially demolishing tunnel temporary and/or permanent lining at cross passage locations and start of mining of the cross passage. At these cross-passage and sump/pump locations, chemical grouting may be required though unlikely, prior to excavation to control the flow of water into the rock zone to be excavated. More details can be found in GDM #9.

Per the DART Design Criteria Manual for underground construction, Section 18.3.2 Excavation Methods, blasting will not be permitted. Hence mechanized excavation equipment such as roadheaders and hydraulic rams will be employed. Roadheaders will facilitate excavation of non-circular geometry SEM structures causing minimal over-break.

7.2 Construction Method for Cross Passages

The sequential excavation method (SEM) is feasible for the cross-passage construction. In general, the planned cross-passage excavations will be situated in the rock mass, and they would provide longer unsupported stand-up time windows between the completion of excavation and installation of initial support than would be the case for soft ground conditions. Regardless of the ground condition, probe drilling for verification of the geotechnical and geological condition shall be a mandatory process prior to partially demolishing tunnel temporary and/or permanent lining at cross passage locations and start of mining of the cross passage. More details can be found in GDM #9.

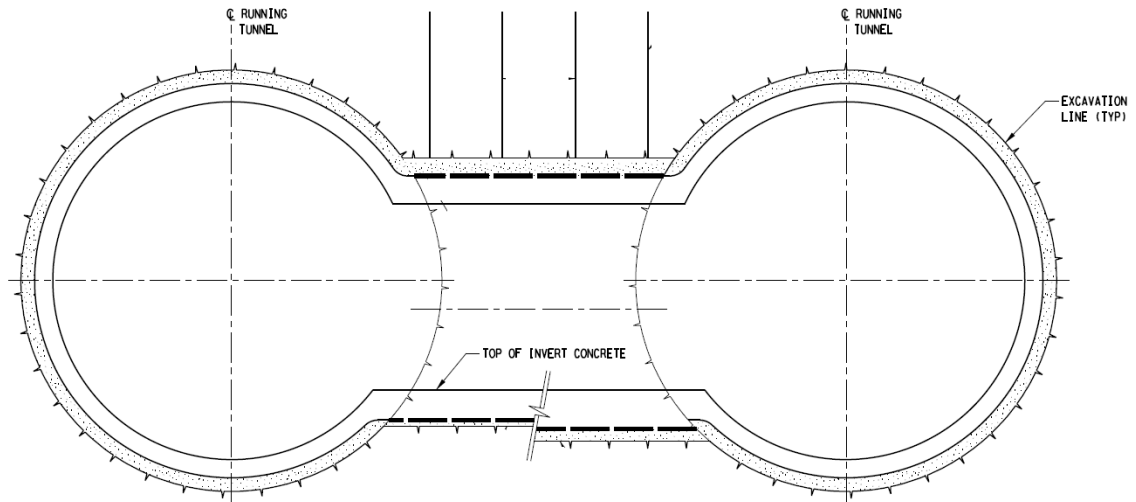

Figure 7-1 Cross-Passage Longitudinal Section

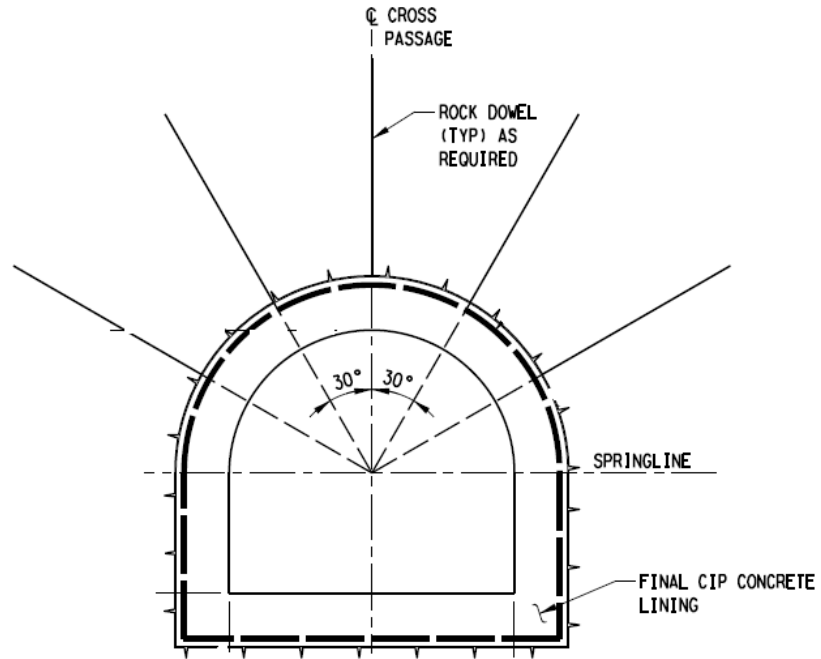

Figure 7-2 Cross-Passage Section for Class I Rock

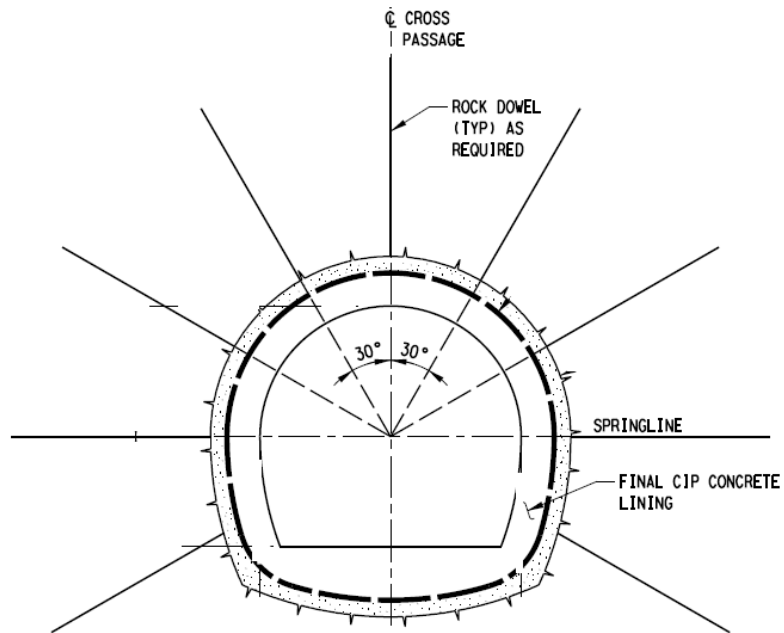

Figure 7-3 Cross-Passage Section for Class II Rock

7.3 Construction Method for Sump Pump Station

The sequential excavation method (SEM) is feasible to use for this sump/pump station excavation at Sta. 66+25 (Figure 7-4) which is the lowest point along the track alignment based on the revision in Aug. 12, 2019. The construction methodology is recommended in the GDM #09 – Construction of Cross Passages, Alcoves, and Pump Rooms (Contract No. GPC6, 2019d). The anticipated rock type below the running tunnel invert may be the Eagle Ford shale. Nonetheless, probe drilling for verification of the geotechnical and geologic condition is recommended for the Sump Pump excavation as well. Under this geological circumstance, the groundwater and methane gas treatment during mining may be a key issue to be resolved.

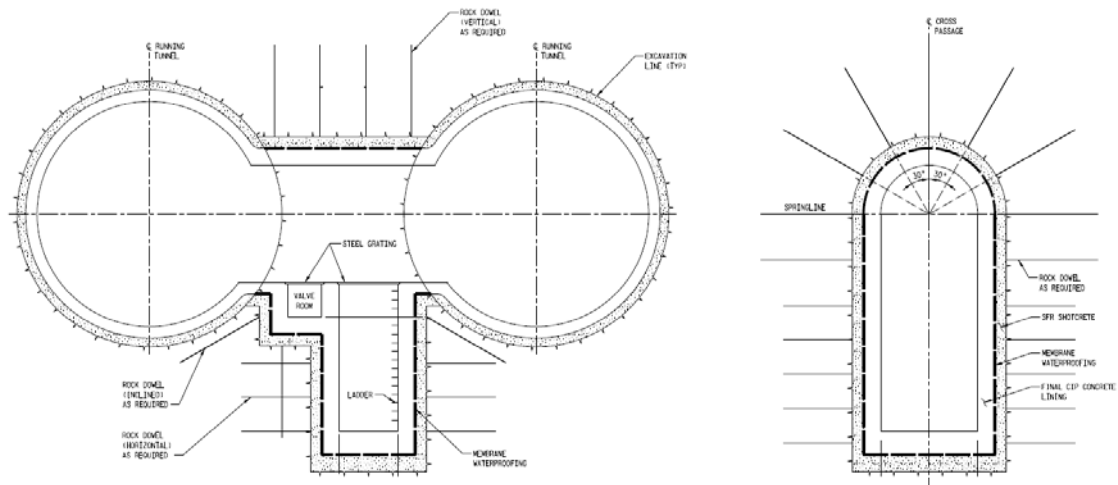

Figure 7-4 Sump/Pump Station Tunnel Profile and Cross-Sections

8 TUNNEL AND STATION WATERPROOFING

It is of paramount importance to protect underground facilities, including tunnels and stations, from the effects of groundwater seeping into these facilities and their internal structures. If left untreated and/or uncontrolled, water infiltrating through final liners or inverters of the completed underground structures would create an uncomfortable environment for its users, accelerate structures deterioration, reduce their service life, and possibly lead to further damages to the surrounding rail and facility systems equipment, including system and electrical cables, as well as to the architectural finishes.

The watertightness of the waterproofing system is recommended to be less than 0.001 gal/ft²/day, with 0.02 gallon per minute of flow from any single leak, in accordance with AASHTO, 2017, LRFD Road Tunnel Design and Construction Guide Specifications, First Edition.

8.1 Application to Underground Structures

Externally applied waterproofing systems constitute an indispensable component of underground transit systems. The customary method of waterproofing tunnels and caverns is in the form of impervious membrane supplemented by geotextile and smoothing shotcrete and other means of protection against punctures and similar damage potentially caused by the surrounding ground. Membrane waterproofing is commonly used for all tunnels and caverns constructed by SEM excavation, TBM tunnels with cast-in-place linings, and cut-and-cover and open cut (U-Wall) construction. For one-pass TBM tunnels with precast concrete segmental linings, waterproofing is achieved by the controlled high-quality construction of the segments and the insertion of gaskets at the joints of adjacent segments instead of waterproofing membranes.

Where the membrane is used on the “blind side” of an underground structure, i.e., the concrete walls or linings are cast against a pre-installed membrane, the area of application is subdivided into isolated compartments bound by water barriers and outfitted with remedial grouting tubes to localize possible seepage of water through unforeseen membrane damage, and provide means of repairing the area of seepage by remedial grouting. In addition, all construction joints are provided with waterstops to prevent seepage through cold joints, should the membrane be damaged in those areas.

8.2 Types of Waterproofing Systems

There are two basic types of waterproofing systems: drained (open) and undrained (closed). Various waterproofing materials are available to form these systems.

Specific characteristics of these waterproofing systems and available materials are presented in detail in GDM #4.



8.3 Waterproofing Systems for DART D2 Project

Considering the geologic and hydrologic conditions, type and configuration of the structure, possible underground tunneling methods to be utilized, the need to provide a dry and functional structure with a design life of a minimum of 100 years and reduced maintenance cost, it is recommended that an undrained synthetic membrane waterproofing system is implemented into the design of the project. These recommendations are based on the south of August 12, 2019 alignment, which is in majority situated in Austin Chalk limestone. Experience has indicated that drained waterproofing systems in similar geologic environments were prone to clogging of draining pipes due to calcification, incurring an additional life-cycle maintenance burden. Due to the hydrologic environment and the potential presence of methane gas in the D2 geology, it is recommended that waterproofing materials selected be resistant to hydrocarbons, such as high-density polyethylene or polyolefin. It is further recommended that a compartmentalized membrane system be applied in order to improve watertightness and reduce life-cycle maintenance costs.



9 POTENTIAL CONSTRUCTION SEQUENCING

Two major construction sequences for the mined tunnel and station section are possible as described below,

- a. Complete running tunnel excavation prior to station cavern excavation.
- b. Complete station cavern excavation first, then begin the running tunnel excavation.

The key factors to be considered when the Contractor selects their preferred option are optimization of mucking operations and environmental issues such as dust, noise and vibration control, which must be addressed by community outreach in the City's downtown area.

Generally, from an aspect of mucking, ventilation and delivery of construction materials, it is recommended to complete at least one of the tunnel bores prior to station cavern excavation.

In constructing the cut-and-cover structures within tight right-of-way (ROW) areas, the "Top-Down" construction sequence may be used to minimize the potential impact to the small business and residential units in the City's downtown area. The more detailed construction sequence is to be reviewed and determined during the future detail design stage.



10 REFERENCES

DART, DART Light Rail Project Design Criteria Manual

GPC6, 2019a. *Geotechnical Data Report*, Dallas CBD Second Light Rail Alignment - DART D-2, August 27, 2019, 899 p.

GPC6, 2019b. *Technical Memorandum 3 (TM 3)*, "Preliminary Ground Characterization," Rev A, C-2012668-02, Task Order #39, Dallas CBD Second Light Rail Alignment (D2 Subway), prepared for DART, January 24, 2019, 74 p.

GPC6, 2019c. *Geotechnical Design Memorandum 11 (GDM 11)*. "Geotechnical Design Memorandum for Critical Structures and Summary of Criteria," Rev A, C-2012668-02, Task Order #39 Dallas CBD Second Light Rail Alignment (D2 Subway), prepared for DART, September 3, 2019, 22 p.

GPC6, 2019d. *Geotechnical Design Memorandum 9 (GDM 9)*. "Construction of Cross Passages, Alcoves, and Pump Rooms," Rev A, C-2012668-02, Task Order #39 Dallas CBD Second Light Rail Alignment (D2 Subway), prepared for DART, September 3, 2019, 36 p.

GPC6, 2019e. *Technical Memorandum 16 (TM 16)*, "Utility Conflicts at Portals and Underground Stations," Rev A, C-2012668-02, Task Order #39 Dallas CBD Second Light Rail Alignment (D2 Subway), prepared for DART, October 1, 2018, 6 p.

GPC6, 2019f. *Technical Memorandum 8 (TM 8)*, "Assessment of Minimum Rock Cover Over Crown," Rev A, C-2012668-02, Task Order #39 Dallas CBD Second Light Rail Alignment (D2 Subway), prepared for DART, September 28, 2018, 27 p.

GPC6, 2019g. *Geotechnical Design Memorandum 2 (GDM 2)*, "Underground Excavation Methods," Rev A, C-2012668-02, Task Order #39 Dallas CBD Second Light Rail Alignment (D2 Subway), prepared for DART, July 19, 2019, 56 p.

National Fire Protection Association (NFPA), 2020. *NFPA 130 Standards for Fixed Guideway Transit and Passenger Rail Systems*.